

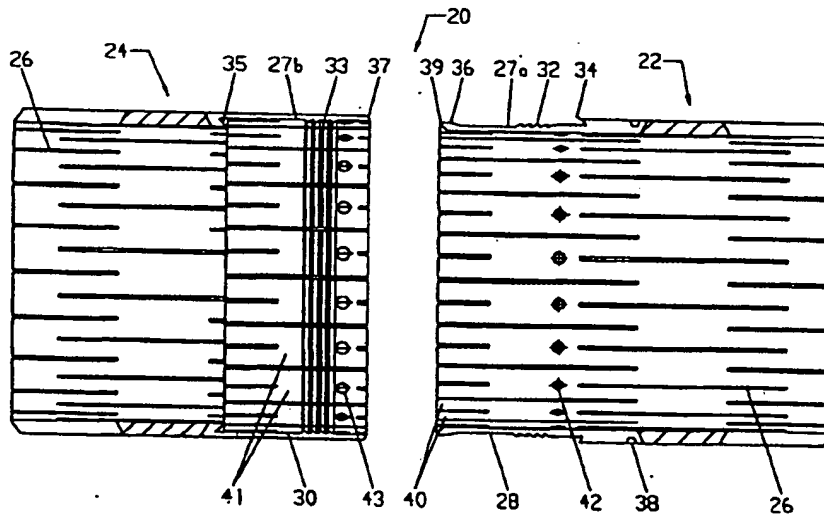

INTERNATIONAL APPLICATION PUBLISHED UNDER THE PATENT COOPERATION TREATY (PCT)

<p>(51) International Patent Classification 6 : E21B 17/08, 43/10, 43/08</p>	<p>A1</p>	<p>(11) International Publication Number: <b>WO 96/37681</b> (43) International Publication Date: 28 November 1996 (28.11.96)</p>
<p>(21) International Application Number: PCT/GB96/01250 (22) International Filing Date: 24 May 1996 (24.05.96) (30) Priority Data: 9510465.9 24 May 1995 (24.05.95) GB (71) Applicant (for all designated States except US): PETROLINE WIRELINE SERVICES LIMITED (GB/GB); Howe Moss Terrace, Kirkehill Industrial Estate, Dyce, Aberdeen AB2 0GR (GB). (72) Inventor; and (75) Inventor/Applicant (for US only): CAMPBELL, Alasdair (GB/GB); 38 Bruce Crescent, Ellon AB41 9BW (GB). (74) Agents: McCALLUM, William, Potter et al.; Cruikshank &amp; Fairweather, 19 Royal Exchange Square, Glasgow G1 3AE (GB).</p>	<p>(81) Designated States: AL, AM, AT, AU, AZ, BB, BG, BR, BY, CA, CH, CN, CZ, DE, DK, EE, ES, FI, GB, GE, HU, IS, JP, KE, KG, KP, KR, KZ, LK, LR, LS, LT, LU, LV, MD, MG, MK, MN, MW, MX, NO, NZ, PL, PT, RO, RU, SD, SE, SG, SI, SK, TJ, TM, TR, TT, UA, UG, US, UZ, VN, ARIPO patent (KE, LS, MW, SD, SZ, UG), Eurasian patent (AM, AZ, BY, KG, KZ, MD, RU, TJ, TM), European patent (AT, BE, CH, DE, DK, ES, FI, FR, GB, GR, IE, IT, LU, MC, NL, PT, SE), OAPI patent (BF, BJ, CF, CG, CI, CM, GA, GN, ML, MR, NE, SN, TD, TG).</p> <p><b>Published</b> <i>With international search report. Before the expiration of the time limit for amending the claims and to be republished in the event of the receipt of amendments.</i></p>	

(54) Title: CONNECTOR ASSEMBLY FOR AN EXPANDABLE SLOTTED PIPE



(57) Abstract

A connector assembly (20) for connecting expandable slotted tubing (EST) (10) comprises tubular first and second parts (22, 24) for mounting on the ends of respective lengths of slotted tubing. The parts (22, 24) are themselves slotted (26). The free end of the first part defines a male portion (28) and the free end of the second part defining a female portion (30), the free ends of the parts being adapted to cogage with one another and to permit expansion of the coupled parts in a corresponding manner to the tubing (10).

**FOR THE PURPOSES OF INFORMATION ONLY**

Codes used to identify States party to the PCT on the front pages of pamphlets publishing international applications under the PCT.

AM	Armenia	GB	United Kingdom	MW	Malawi
AT	Austria	GE	Georgia	MX	Mexico
AU	Australia	GN	Ghana	NE	Niger
BB	Barbados	GR	Greece	NL	Netherlands
BE	Belgium	HU	Hungary	NO	Norway
BF	Burkina Faso	IE	Ireland	NZ	New Zealand
BG	Bulgaria	IT	Italy	PL	Poland
BJ	Benin	JP	Japan	PT	Portugal
BR	Brazil	KE	Kenya	RO	Romania
BY	Belarus	KG	Kyrgyzstan	RU	Russian Federation
CA	Canada	KP	Democratic People's Republic of Korea	SD	Sudan
CF	Central African Republic	KR	Republic of Korea	SE	Sweden
CG	Congo	KZ	Kazakhstan	SG	Singapore
CH	Switzerland	LI	Liechtenstein	SI	Slovenia
CI	Côte d'Ivoire	LK	Sri Lanka	SK	Slovakia
CM	Cameroon	LR	Liberia	SN	Senegal
CN	China	LT	Lithuania	SZ	Swaziland
CS	Czechoslovakia	LU	Luxembourg	TD	Chad
CZ	Czech Republic	LV	Latvia	TC	Togo
DE	Germany	MC	Monaco	TJ	Tajikistan
DK	Denmark	MD	Republic of Moldova	TT	Trinidad and Tobago
EE	Estonia	MG	Madagascar	UA	Ukraine
ES	Spain	ML	Mali	UG	Uganda
FI	Finland	MN	Mongolia	US	United States of America
FR	France	MR	Mauritania	UZ	Uzbekistan
GA	Gabon			VN	Viet Nam

## CONNECTOR ASSEMBLY FOR AN EXPANDABLE SLOTTED PIPE

This invention relates to a connector assembly for use in connecting sections of expandable tubing, and in particular but not exclusively for use in the connection of sections of expandable slotted tubing (EST) as utilised in downhole applications in the oil and gas exploration and extraction industries.

Expandable slotted tubing (EST), such as described in WO93\25800 (Shell Internationale Research Maatschappij B.V.), may be used in various downhole applications. The tubing comprises lengths of tube which have been machined to create a large number of longitudinal slots. Thus, it is relatively easy to expand the tube radially outwardly by, for example, running a mandrel through the tubing. The expansion causes the slots to extend to create diamond-shaped apertures. The tubing is useful where it is desired to, for example, line a bore below a restriction without further reducing the diameter of the bore. Using conventional tubing the outer diameter of the tubing must, by necessity, be of smaller diameter than the restriction, to permit the tubing to be passed through the restriction. This reduction in the bore diameter has a number of significant effects, primarily in reducing the production capabilities of the bore. Using EST, the tubing may pass through a restriction into a reamed section of bore below the restriction. The tubing may then be expanded to a diameter larger than the restriction.

EST is supplied in lengths which are, at present, made up into a string by welding the lengths to one another. This is relatively time consuming and expensive and in many situations, for example in an off-shore operation in bad weather, it may be difficult to maintain consistent weld quality. Safety problems may also arise due to the high temperatures and exposed flames or sparks created by a welding operation. Further, in the event of a "mis-run", requiring the welded lengths of tube forming the EST string to be separated, the tubing must be cut, and the cut tubing

may not be suitable for re-use.

It is among the objectives of the present invention to provide a means of connecting sections of EST which obviates or mitigates these difficulties.

5 According to the present invention there is provided a connector assembly for connecting expandable slotted tubing, the assembly comprising tubular first and second parts for mounting on the ends of respective lengths of slotted tubing, the parts being slotted and the free end of the first part defining a male portion and the free end of 10 the second part defining a female portion such that the free ends of the parts are adapted to engage with one another and to permit expansion of the coupled parts in a corresponding manner to the tubing.

15 According to a further aspect of the present invention there is provided a method of connecting expandable slotted tubing, the method comprising:

providing first and second lengths of slotted tubing;  
providing tubular slotted first and second parts on 20 the ends of the respective tubing lengths, the free end of the first part defining a male portion and the free end of the second part defining a corresponding female portion;  
and

25 coupling said male and female portions to connect the first and second tubing lengths.

The invention further relates to a method of locating such connected lengths of slotted tubing in a bore, including the step of radially expanding the lengths of tubing and said first and second parts to form a length of 30 expanded tubing of substantially constant internal diameter.

As used herein, the term "slotted" or "slots" is intended to encompass any cutting, machining or weakening of a tubular structure intended to facilitate radial expansion, including: slots which extend only partially 35 through the tube wall and which permit the remaining thinned wall sections to fracture or extend; and lines of

drilled holes.

The parts may be arranged with the respective slots aligned, though this is not considered essential to the successful expansion of the assembly.

5 Preferably, the parts define corresponding screw threads, such that the parts may be made up by relative rotation. Alternatively, the parts may be adapted to allow make up by stabbing in or most preferably by a combination of stabbing and rotation.

10 In a preferred arrangement fasteners are provided for securing the parts to one another; this prevents radial separation of the free ends of the parts when the connected tubing is expanded and prevents rotation of one part relative to the other. Most preferably, fasteners are  
15 located adjacent the free end of the outer female portion, to prevent the end from flaring outwardly on the tubing being expanded. The fasteners may be releasable, for example short screws for location in appropriate holes provided in the parts, such that the tubing may be  
20 separated in the event of a mis-run. The use of screws and the like, and the associated screw-holes, also provides a convenient means for ensuring that the parts are in a desired alignment.

25 Preferably also, the parts define corresponding threads and are also securable to one another by fasteners. Most preferably, the fasteners engage the female portion between the free end and the threaded portion thereof. This arrangement may be provided at any point in the slot  
30 pattern. In an alternative arrangement fasteners may also be provided to engage the male portion between the free end and the threaded portion thereof. With this arrangement it is preferred that threaded portions are located on the "nodes" of the parts, between the slot ends, that are not deformed by expansion of the assembly.

35 Preferably also, the portion of each part for engaging the free end of the other part includes an undercut ledge or groove, and the free end of the other part defines a

tongue to locate in the groove. One or both of said portions may define a back angle to engage with a lip on the end of the other part. This minimises the possibility of the free ends flaring on expansion of the tube; such flaring of the male end would create an irregularity in the tubing bore on which tools might be snagged. Where the parts are threaded, the lipped free end of the male portion is preferably arranged to deflect inwardly to pass the female thread, and to allow the parts to be at least partially made-up by stabbing in. Such deflection may be accommodated by providing a living hinge on the male portion.

The parts may be formed integrally with the respective tubing lengths, or may be welded or otherwise secured thereto; the welding or securing operation may be carried out in a manufacturing or assembly facility, such that the tubing lengths may be delivered to sites ready for connection.

External shoulders may be provided on the connector assembly on one or both parts to facilitate handling of the assembly and the connected tubing. Preferably, the shoulders are provided at nodes of the parts.

These and other aspects of the present invention will now be described, by way of example, with reference to the accompanying drawings, in which:

Figure 1 is a sectional view of a length of expandable slotted tubing (EST), shown in an expanded configuration;

Figure 2 is a sectional view on line 2 - 2 of Figure 1, and also shows the EST in unexpanded configuration;

Figure 3 is a half section of a connector assembly in accordance with a preferred embodiment of the present invention, with the parts of the assembly shown separated; and

Figure 4 is a half section of the connector assembly of Figure 3, showing the parts connected.

Reference is first made to Figures 1 and 2 of the drawings, which illustrate a length of expandable slotted

tubing (EST) 10. In its initial configuration, the tubing 10 is simply a length of pipe in which a series of longitudinal slots 12 have been machined (shown as tube 10a with slots 12a in Figure 2). Applying a radially outward force to the tubing wall, for example by passing a mandrel through the tubing, causes the tube to expand such that the slots 12a become diamond shaped openings 12b, as described in WO93\25800.

The tubing 10 is supplied in lengths suitable for transportation and handling and these are joined to one another on surface to create a tubular string. The connector assembly 20 as illustrated in Figures 3 and 4 of the drawings is used to connect such tubing lengths. The assembly 20 comprises a first part 22 and a second part 24, which are mounted on the ends of the respective tubing lengths. In this particular example the parts 22, 24 are adapted to be welded to the tubing ends. The parts 22, 24 are intended to expand in a similar manner to the tubing 10, and as such are provided with similar longitudinal slots 26.

The free end of the first part 22 is machined to form a male portion 28 and the free end of the second part 22 defines a corresponding female portion 30 adapted to receive the male portion 28, as will be described. Both portions 28, 30 carry corresponding screw threads 32, 33 such that the parts 22, 24 may be made up by relative rotation. The threads are located on the "nodes" 27a, 27b of the fingers 40, 41 formed by the slots 26, that is the areas between the slot ends which remain substantially undeformed following expansion of the assembly 20.

Each part 22, 24 also defines a respective undercut ledge 34, 35 for engaging the free end of the other part 36, 37, which is of corresponding form. The ledge 35 formed on the second part 24 defines a back angle and cooperates with a radially extending lip 39 on the free end of the first part 36. This serves to prevent the free ends of one part separating from the other part on expansion of

the tubing. To permit the free end 36 of the first part to be deflected inwardly, allowing the lip 39 to pass within the screw thread 33 on the second part, the first part 22 defines a living hinge 38. It will be noted that the hinge 38 is spaced a relatively long distance from the free end 36, such that only small degree of deflection is necessary at the hinge 38 to allow the free end 36 to pass the screw threads 33.

As noted above, the slots 26 in the parts 22, 24 are arranged such that the free ends 36, 37 of the parts each define fingers 40, 41, and each of these fingers defines a hole 42, 43. The holes 43 in the second part are counter-sunk, whereas the holes 42 in the first part 22 are threaded such that the fingers 40, 41 may be secured to one another using a number of short screws 44. The screws 44 are located adjacent the free end of the second part, as the fingers 41 will have a tendency to flare outwardly on expansion of the tubing. In addition, a line of screws may also be provided on the other side of the threads 32, 33, and in this case it may not be necessary to provide a back angle on the ledge 35, as the additional set of screws will prevent the expanded fingers 40 from separating from the expanded part 24. If the back angle on the ledge 35 is not required, the radially extending lip 39 may be omitted and thus there is no requirement to provide the living hinge 38.

To connect two lengths of tubing provided with the tubing connector assembly 20, the parts 22, 24 are brought together, or stabbed in, such that the free end 36 of the first part passes inside the free end 37 of the second part, the end 36 being deflected inwardly to ride under the screw thread 33. Once the screw threads 32, 33 come together the first part 22 is rotated relative to the second part 24 until the parts 22, 24 are securely engaged. If necessary, the first part 22 is then rotated in the opposite direction to bring the holes 42, 43 into alignment, which also serves to bring the slots 26 in the



parts 22, 24 into alignment. The screws 44 are then secured in the holes 42, 43.

5 The desired number of tubing sections are connected in this manner to form a string and run downhole to the desired location within the bore. The tubing and the connector assemblies may then be expanded to the desired diameter. However, in the event of a mis-run, requiring the tubing to be withdrawn and disassembled, this may be achieved relatively easily by removing the screws 44, 10 unscrewing the first and second parts 22, 24 and then withdrawing the male portion 28 from the female portion 30.

15 It will be clear to those of skill in the art that the above-described embodiment is merely exemplary of the present invention, and may be subject to various modifications and improvements without departing from the scope of the invention.

CLAIMS

1. A connector assembly (20) for connecting expandable slotted tubing (10), the assembly comprising tubular first and second parts (22, 24) for mounting on the ends of  
5 respective lengths of slotted tubing, the parts being slotted (26) and the free end of the first part defining a male portion (28) and the free end of the second part defining a female portion (30) such that the free ends of the parts are adapted to engage with one another and to  
10 permit expansion of the coupled parts in a corresponding manner to the tubing.
2. The connector assembly of claim 1 wherein the parts (22, 24) are arranged with the respective slots (26) aligned.
- 15 3. The connector assembly of claim 1 or 2, wherein the parts (22, 24) define corresponding screw threads (32, 33), such that the parts may be made up by relative rotation.
- 20 4. The connector assembly of claim 1, 2 or 3, wherein the parts (22, 24) are adapted to allow make up by stabbing in.
5. The connector assembly of any of the preceding claims wherein the parts (22, 24) define corresponding screw threads (32, 33) and are adapted to allow make up by a combination of stabbing in and rotation.
- 25 6. The connector assembly of any of the preceding claims wherein fasteners (44) are provided for securing the parts (22, 24) to one another.
7. The connector assembly of claim 6, wherein the fasteners (44) are located adjacent the free end of the

female portion (30), to prevent the end from flaring outwardly on the tubing being expanded.

8. The connector assembly of claim 6 or 7, wherein the fasteners (44) are releasable.

5 9. The connector assembly of claim 8, wherein the fasteners are screws (44) for location in appropriate holes (42, 43) provided in the parts (22, 24), such that the tubing may be separated in the event of a mis-run.

10 10. The connector assembly of any of the preceding claims wherein the parts (22, 24) define corresponding threads (32, 33) and are also securable to one another by fasteners (44).

15 11. The connector assembly of claim 10, wherein the fasteners (44) engage the female portion (30) between its free end and the thread (33) thereon.

12. The connector assembly of claim 11, wherein fasteners are also provided to engage the male portion (28) between its free end and the thread (32) thereon.

20 13. The connector assembly of any of the preceding claims, wherein the parts (22, 24) define corresponding screw threads (32, 33) and the threads are located on the nodes of the parts.

25 14. The connector assembly of any of the preceding claims wherein the portion of each part (22, 24) for engaging the free end of the other part (24, 22) includes an undercut groove (34, 35), and the free end of the other part defines a tongue (37, 36) to locate in the groove (34, 35).

15. The connector assembly of claim 14, wherein at least one of said portions defines a back angle to engage with a

lip (39) on the end of the other part.

16. The connector assembly of claim 15, wherein the free end of the male portion (28) is provided with a lip (39) and is arranged to deflect inwardly to allow the parts to be at least partially made-up by stabbing in.

17. The connector assembly of claim 16, wherein said deflection is accommodated by providing a living hinge (38) on the male portion (28).

18. The connector assembly of any of the preceding claims wherein the parts (22, 24) are formed integrally with the respective tubing lengths (10).

19. The connector assembly of any of claims 1 to 17, wherein the parts (22, 24) are adapted to be welded to the respective tubing lengths (10).

20. The connector assembly of any of the preceding claims wherein external shoulders are provided on one or both parts (22, 24) to facilitate handling of the assembly (20) and the connected tubing (10).

21. The connector assembly of claim 20, wherein the shoulders are provided at nodes of the parts (22, 24).

22. A method of locating lengths of slotted tubing (10) connected with the connector assembly (20) of any of the preceding claims in a bore, including the step of radially expanding the lengths of tubing (10) and said first and second parts (22, 24) to form a length of expanded tubing of substantially constant internal diameter.

23. A method of connecting expandable slotted tubing, the method comprising:

providing first and second lengths of slotted tubing

(10);

5 providing tubular slotted first and second parts (22, 24) on the ends of the respective tubing lengths (10), the free end of the first part defining a male portion (28) and the free end of the second part defining a corresponding female portion (30); and

coupling said male and female portions (28, 30) to connect the first and second tubing lengths (10).

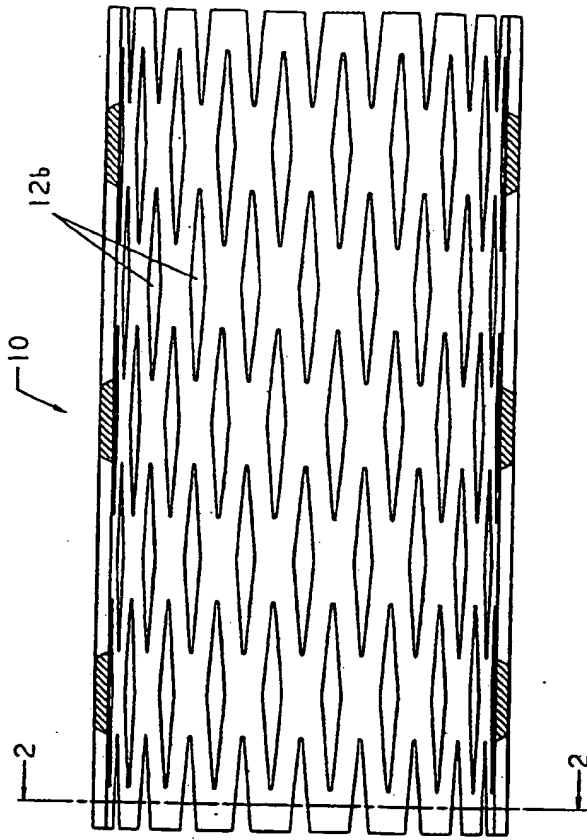

Figure 1

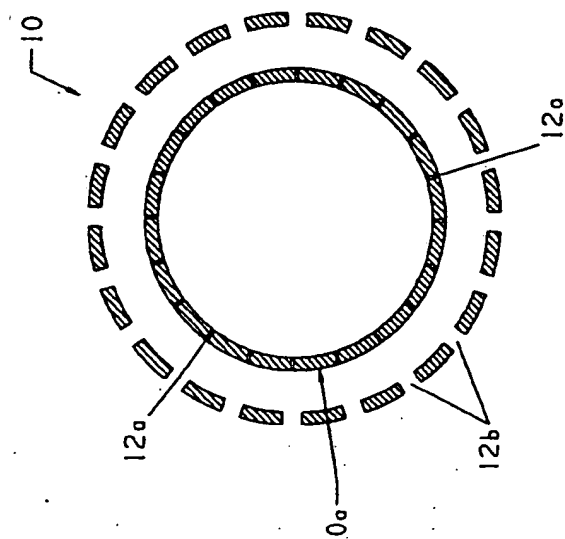

Figure 2

SUBSTITUTE SHEET (RULE 26)

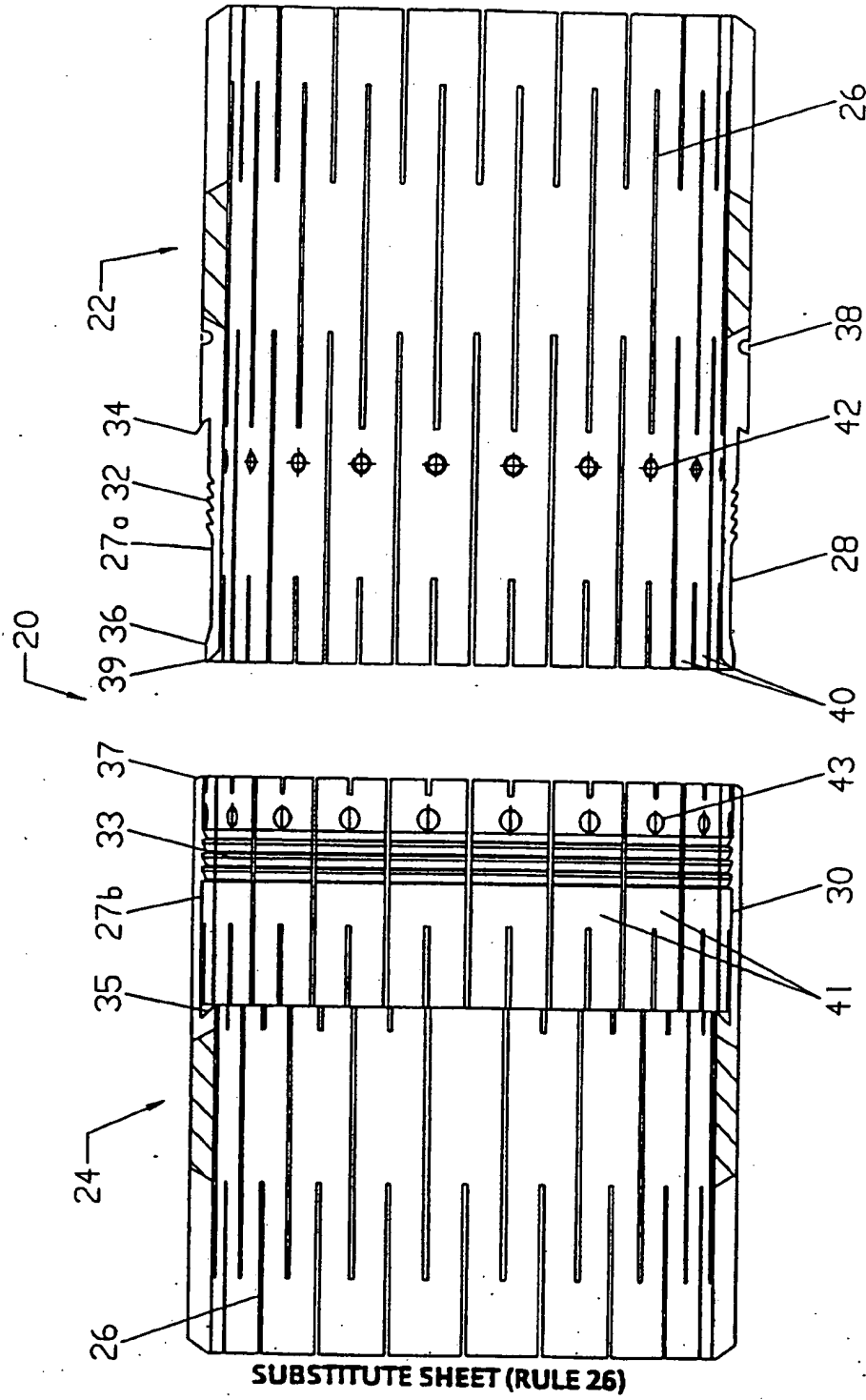

Figure 3

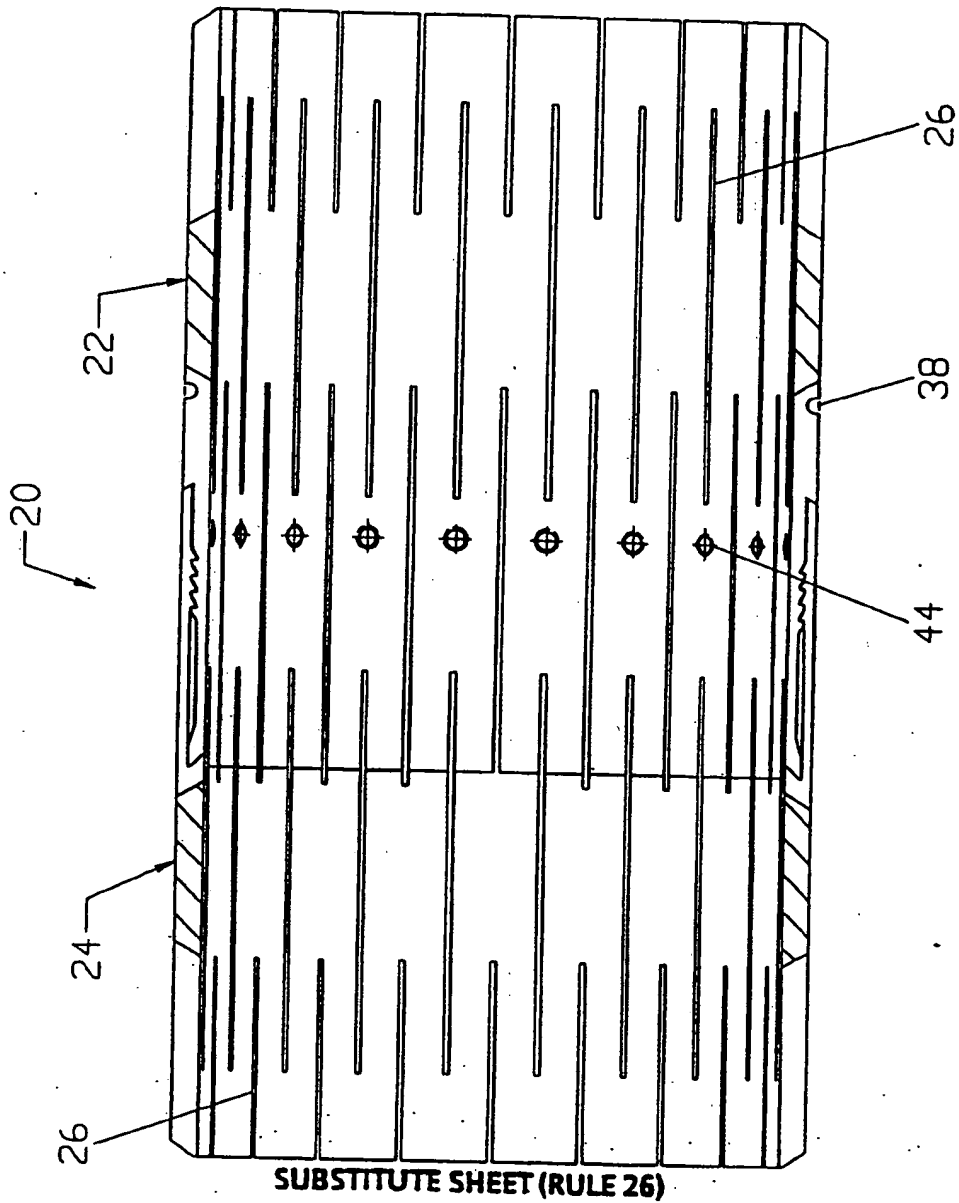

Figure 4



INTERNATIONAL SEARCH REPORT

International Application No.  
PCT/GB 96/01250

<b>A. CLASSIFICATION OF SUBJECT MATTER</b> IPC 6 E21B17/08 E21B43/10 E21B43/08		
According to International Patent Classification (IPC) or to both national classification and IPC		
<b>B. FIELDS SEARCHED</b> Minimum documentation searched (classification system followed by classification symbols) IPC 6 E21B F16L		
Documentation searched other than minimum documentation to the extent that such documents are included in the fields searched		
Electronic data base consulted during the international search (name of data base and, where practical, search terms used)		
<b>C. DOCUMENTS CONSIDERED TO BE RELEVANT</b>		
Category*	Citation of document, with indication, where appropriate, of the relevant passages	Relevant to claim No.
A	FR,A,1 565 562 (RABUEL) 2 May 1969 see page 2, left-hand column, line 43 - right-hand column, line 4	1,22,23
A	FR,A,2 359 358 (SOCIETE ANONYME FRANCAISE DU FERODO) 17 February 1978 see page 2, line 21 - page 3, line 30	1,22,23
A	US,A,4 349 050 (BERGSTROM) 14 September 1982 see column 2, line 6 - column 3, line 6	1,22,23
A	US,A,2 633 374 (BOICE) 31 March 1953 see column 3, line 67 - column 4, line 4	1,22,23
A	WO,A,92 01139 (NOBILEAU) 23 January 1992 see abstract	1,22,23
-/--		
<input checked="" type="checkbox"/> Further documents are listed in the continuation of text C. <input checked="" type="checkbox"/> Patent family members are listed in annex.		
* Special categories of cited documents : *A* document defining the general state of the art which is not considered to be of particular relevance *E* earlier document not published on or after the international filing date *L* document which may throw doubts on priority claim(s) or which is cited to establish the publication date of another citation or other special reason (as specified) *O* document referring to an oral disclosure, use, exhibition or other means *P* document published prior to the international filing date but later than the priority date claimed *T* later document published after the international filing date or priority date and not in conflict with the application but cited to understand the principle or theory underlying the invention *X* document of particular relevance; the claimed invention cannot be considered novel or cannot be considered to involve an inventive step when the document is taken alone *Y* document of particular relevance; the claimed invention cannot be considered to involve an inventive step when the document is combined with one or more other such documents, such combination being obvious to a person skilled in the art. *A* document member of the same patent family		
Date of the actual completion of the international search  24 September 1996		Date of mailing of the international search report  26.09.96
Name and mailing address of the ISA European Patent Office, P.B. 5818 Patentlaan 2 NL - 2280 HV Rijswijk Tel. (+31-70) 340-2040, Tx. 31 651 epo nl. Fax (+31-70) 340-3016		Authorized officer  Sogno, M

INTERNATIONAL SEARCH REPORT

International Application No  
PCT/GB 96/01250

C (Continuation) DOCUMENTS CONSIDERED TO BE RELEVANT

Category	Citation of document, with indication, where appropriate, of the relevant passages	Relevant to claim No.
A	DE,U,87 06 962 (INTERATOM GMBH) 24 September 1987 see page 3, line 6 - line 29 ---	1,22,23
A	WD,A,93 25800 (SHELL INTERNATIONALE RESEARCH MAATSCHAPPIJ B.V.) 23 December 1993 cited in the application see abstract ---	1,22,23
A	GB,A,792 886 (HUNTSINGER) 2 April 1958 see the whole document ---	1,22,23
A	DE,A,40 10 234 (KARL SCHÖNGEN KG FORMENBAU UND KUNSTOFFVERARBEITUNG) 2 October 1991 see claim 1 ---	1,22,23
A	DE,C,41 33 802 (HAWERKAMP) 22 October 1992 see abstract -----	1,22,23

1

# INTERNATIONAL SEARCH REPORT

Information on patent family members

International Application No  
PCT/GB 96/01250

Patent document cited in search report	Publication date	Patent family member(s)	Publication date
FR-A-1565562	02-05-69	NONE	
FR-A-2359358	17-02-78	DE-A- 2732493 JP-A- 53034118	26-01-78 30-03-78
US-A-4349050	14-09-82	NONE	
US-A-2633374	31-03-53	NONE	
WO-A-9201139	23-01-92	FR-A- 2664355 AU-A- 8104091 EP-A- 0536256 US-A- 5425559	10-01-92 04-02-92 14-04-93 20-06-95
DE-U-8706962	24-09-87	NONE	
WO-A-9325800	23-12-93	AU-A- 4324593 CA-A- 2137565 EP-A- 0643795 JP-T- 7507611 NO-A- 944746 NZ-A- 253125 US-A- 5366012	04-01-94 23-12-93 22-03-95 24-08-95 03-02-95 27-02-96 22-11-94
GB-A-792886		NONE	
DE-A-4010234	02-10-91	NONE	
DE-C-4133802	22-10-92	NONE	